

# CS140 – Operating Systems

**Instructor:** David Mazières

**CAs:** Ashok Cutkosky, Matthew Denton, Brendon Go,  
Saachi Jain, and Diveesh Singh

Stanford University

# Outline

1 Administrivia

2 Substance

# Administrivia

- **Class web page:** <http://cs140.scs.stanford.edu/>
  - All assignments, handouts, lecture notes on-line
- **Textbook: *Operating System Concepts, 8th Edition*, by Silberschatz, Galvin, and Gagne**
  - 9th edition is way more expensive, I haven't looked at it
  - Trying to ween class from textbook anyway—consider it optional
- **Goal is to make lecture slides the primary reference**
  - Almost everything I talk about will be on slides
  - PDF slides contain [links](#) to further reading about topics
  - Please download slides from [class web page](#)

# Administrivia 2

- **Staff mailing list:** `cs140-staff@scs.stanford.edu`
  - Please mail staff list rather than individuals for help
- **Google group [18wi-cs140](#) is main discussion forum**
- **Key dates:**
  - Lectures: MW 3:00pm–4:20pm, Skilling
  - Section: 6 Fridays, time/location TBD, starting this Friday
  - Midterm: Monday, February 12, 3:00–4:20pm (in class)
  - Final: Monday, March 19th, 3:30pm–6:30pm
- **Exams open note, but not open book**
  - Bring notes, slides, any printed materials *except* textbook
  - No electronic devices permitted

# Lecture videos

- **Lectures will be televised for SCPD students**
  - Can also watch if you miss a lecture, or to review
  - But resist temptation to miss a bunch of lectures and watch them all at once
- **SCPD students welcome to attend lecture in person**
- **Other notes for SCPD students:**
  - Please attend exams in person if possible
  - Feel free to use google group to find project partners

# Course topics

- **Threads & Processes**
- **Concurrency & Synchronization**
- **Scheduling**
- **Virtual Memory**
- **I/O**
- **Disks, File systems**
- **Protection & Security**
- **Virtual machines**
- **Note: Lectures will often take Unix as an example**
  - Most current and future OSes heavily influenced by Unix
  - Won't talk much about Windows

# Course goals

- **Introduce you to operating system concepts**
  - Hard to use a computer without interacting with OS
  - Understanding the OS makes you a more effective programmer
- **Cover important systems concepts in general**
  - Caching, concurrency, memory management, I/O, protection
- **Teach you to deal with larger software systems**
  - Programming assignments much larger than many courses
  - **Warning: Many people will consider course very hard**
  - In past, majority of people report  $\geq 15$  hours/week
- **Prepare you to take graduate OS classes (CS240, 240[a-z])**

# Programming Assignments

- **Implement parts of Pintos operating system**
  - Built for x86 hardware, you will use hardware emulator
- **One setup homework (lab 0) due this Friday**
- **Four implementation projects:**
  - Threads
  - User processes
  - Virtual memory
  - File system
- **Lab 1 distributed at end of this week**
  - Attend section this Friday for project 1 overview
- **Implement projects in groups of up to 3 people**
  - Pick your partners today (lecture may end early for this)
  - Please disclose if you are planning to take class pass/fail



# Grading

- **No incompletes**
  - Talk to instructor ASAP if you run into real problems
- **50% of grade based on exams using this quantity:**  
 $\max(\text{midterm} > 0 ? \text{final} : 0, \frac{1}{2}(\text{midterm} + \text{final}))$
- **50% of grade from projects**
  - For each project, 50% of score based on passing test cases
  - Remaining 50% based on design and style
- **Most people's projects pass most test cases**
  - Please, please, please turn in working code, or **no credit** here
- **Means design and style matter a lot**
  - Large software systems not just about producing working code
  - Need to produce code other people can understand
  - That's why we have group projects

# Style

- **Must turn in a design document along with code**
  - We supply you with templates for each project's design doc
- **CAs will manually inspect code for correctness**
  - E.g., must actually implement the design
  - Must handle corner cases (e.g., handle `malloc` failure)
- **Will deduct points for error-prone code w/o errors**
  - Don't use global variables if automatic ones suffice
  - Don't use deceptive names for variables
- **Code must be easy to read**
  - Indent code, keep lines and (when possible) functions short
  - Use a uniform coding style (try to match existing code)
  - Put comments on structure members, globals, functions
  - Don't leave in reams of commented-out garbage code

# Assignment requirements

- **Do not look at other people's solutions to projects**
  - We reserve the right to run **MOSS** on present and past submissions
  - Do not publish your own solutions in violation of the **honor code**
  - **That means using (public) github can get you in big trouble**
- **You may read but not copy other OSEs**
  - E.g., Linux, OpenBSD/FreeBSD, etc.
- **Cite any code that inspired your code**
  - As long as you cite what you used, it's not cheating
  - In worst case, we deduct points if it undermines the assignment
- **Projects due Fridays (before section—TBD)**
- **Ask `cs140-staff` for extension if you run into trouble**
  - Be sure to tell us: How much have you done? How much is left?  
When can you finish by?

# Outline

1 Administrivia

2 Substance

# What is an operating system?

- Layer between applications and hardware

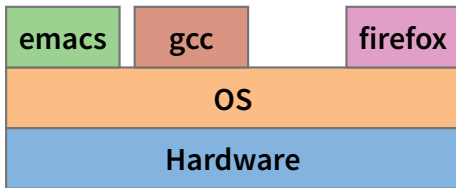

- Makes hardware useful to the programmer
- [Usually] Provides abstractions for applications
  - Manages and hides details of hardware
  - Accesses hardware through low/level interfaces unavailable to applications
- [Often] Provides protection
  - Prevents one process/user from clobbering another

# Why study operating systems?

- **Operating systems are a mature field**
  - Most people use a handful of mature OSES
  - Hard to get people to switch operating systems
  - Hard to have impact with a new OS
- **High-performance servers are an OS issue**
  - Face many of the same issues as OSES
- **Resource consumption is an OS issue**
  - Battery life, radio spectrum, etc.
- **Security is an OS issue**
  - Hard to achieve security without a solid foundation
- **New “smart” devices need new OSES**
- **Web browsers increasingly face OS issues**

# Primitive Operating Systems

- **Just a library of standard services [no protection]**

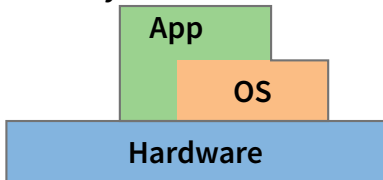

- Standard interface above hardware-specific drivers, etc.
- **Simplifying assumptions**
  - System runs one program at a time
  - No bad users or programs (often bad assumption)
- **Problem: Poor utilization**
  - ...of hardware (e.g., CPU idle while waiting for disk)
  - ...of human user (must wait for each program to finish)

# Multitasking

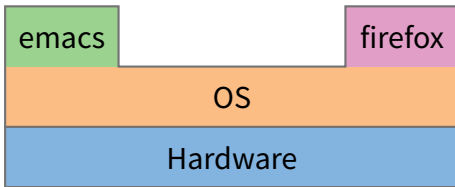

- **Idea: More than one process can be running at once**
  - When one process blocks (waiting for disk, network, user input, etc.) run another process
- **Problem: What can ill-behaved process do?**



# Multitasking

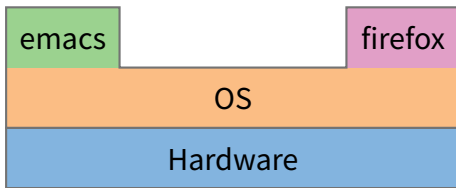

- **Idea: More than one process can be running at once**
  - When one process blocks (waiting for disk, network, user input, etc.) run another process
- **Problem: What can ill-behaved process do?**
  - Go into infinite loop and never relinquish CPU
  - Scribble over other processes' memory to make them fail
- **OS provides mechanisms to address these problems**
  - *Preemption* – take CPU away from looping process
  - *Memory protection* – protect process's memory from one another

# Multi-user OSES

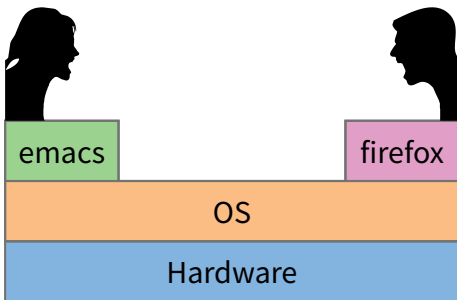

- Many OSES use *protection* to serve distrustful users/apps
- **Idea:** With  $N$  users, system not  $N$  times slower
  - Users' demands for CPU, memory, etc. are bursty
  - Win by giving resources to users who actually need them
- **What can go wrong?**

# Multi-user OSeS

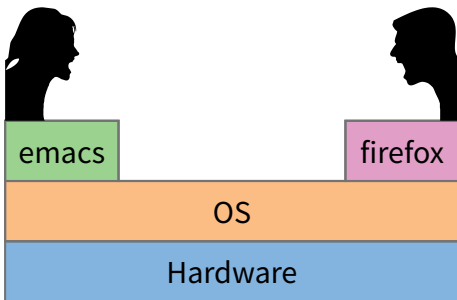

- Many OSeS use *protection* to serve distrustful users/apps
- **Idea: With  $N$  users, system not  $N$  times slower**
  - Users' demands for CPU, memory, etc. are bursty
  - Win by giving resources to users who actually need them
- **What can go wrong?**
  - Users are gluttons, use too much CPU, etc. (need policies)
  - Total memory usage greater than in machine (must virtualize)
  - Super-linear slowdown with increasing demand (thrashing)

# Protection

- **Mechanisms that isolate bad programs and people**
- **Pre-emption:**
  - Give application a resource, take it away if needed elsewhere
- **Interposition/mediation:**
  - Place OS between application and “stuff”
  - Track all pieces that application allowed to use (e.g., in table)
  - On every access, look in table to check that access legal
- **Privileged & unprivileged modes in CPUs:**
  - Applications unprivileged (unprivileged *user* mode)
  - OS privileged (privileged supervisor/*kernel* mode)
  - Protection operations can only be done in privileged mode

# Typical OS structure

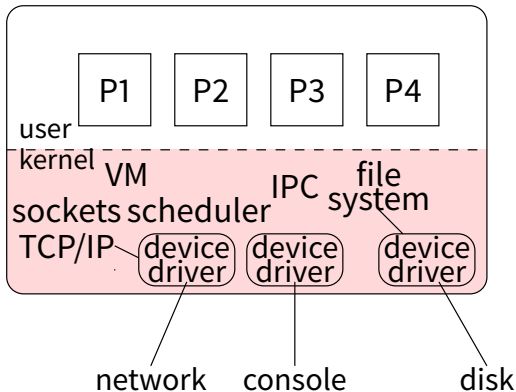

- Most software runs as user-level processes (P[1-4])
- OS *kernel* runs in *privileged* mode (shaded)
  - Creates/deletes processes
  - Provides access to hardware

# System calls

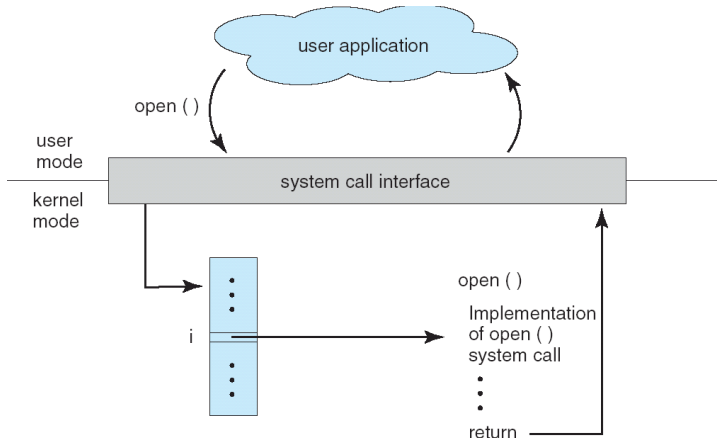

- Applications can invoke kernel through *system calls*
  - Special instruction transfers control to kernel
  - ... which dispatches to one of few hundred syscall handlers

# System calls (continued)

- **Goal: Do things application can't do in unprivileged mode**
  - Like a library call, but into more privileged kernel code
- **Kernel supplies well-defined *system call* interface**
  - Applications set up syscall arguments and *trap* to kernel
  - Kernel performs operation and returns result
- **Higher-level functions built on syscall interface**
  - `printf`, `scanf`, `fgets`, etc. all user-level code
- **Example: POSIX/UNIX interface**
  - `open`, `close`, `read`, `write`, ...

# System call example

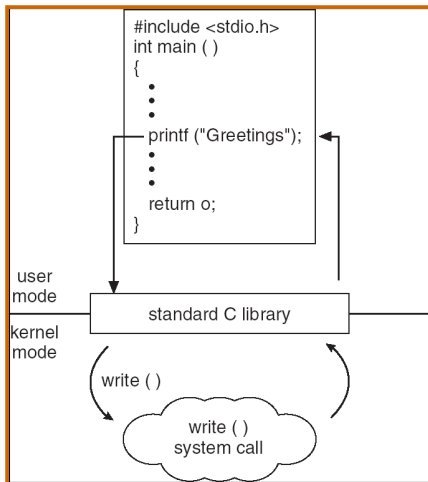

- **Standard library implemented in terms of syscalls**
  - *printf* – in *libc*, has same privileges as application
  - calls *write* – in kernel, which can send bits out serial port



# UNIX file system calls

- **Applications “open” files (or devices) by name**
  - I/O happens through open files
- `int open(char *path, int flags, /*int mode*/...);`
  - flags: `O_RDONLY`, `O_WRONLY`, `O_RDWR`
  - `O_CREAT`: create the file if non-existent
  - `O_EXCL`: (w. `O_CREAT`) create if file exists already
  - `O_TRUNC`: Truncate the file
  - `O_APPEND`: Start writing from end of file
  - mode: final argument with `O_CREAT`
- **Returns file descriptor—used for all I/O to file**

# Error returns

- **What if `open` fails? Returns -1 (invalid fd)**
- **Most system calls return -1 on failure**
  - Specific kind of error in global int `errno`
- `#include <sys/errno.h>` **for possible values**
  - 2 = `ENOENT` “No such file or directory”
  - 13 = `EACCES` “Permission Denied”
- `perror` **function prints human-readable message**
  - `perror ("initfile");`  
→ “initfile: No such file or directory”

# Operations on file descriptors

- `int read (int fd, void *buf, int nbytes);`
  - Returns number of bytes read
  - Returns 0 bytes at end of file, or -1 on error
- `int write (int fd, const void *buf, int nbytes);`
  - Returns number of bytes written, -1 on error
- `off_t lseek (int fd, off_t pos, int whence);`
  - `whence`: 0 – start, 1 – current, 2 – end
    - ▶ Returns previous file offset, or -1 on error
- `int close (int fd);`

# File descriptor numbers

- **File descriptors are inherited by processes**
  - When one process spawns another, same fds by default
- **Descriptors 0, 1, and 2 have special meaning**
  - 0 – “standard input” (`stdin` in ANSI C)
  - 1 – “standard output” (`stdout`, `printf` in ANSI C)
  - 2 – “standard error” (`stderr`, `perror` in ANSI C)
  - Normally all three attached to terminal
- **Example:** `type .c`
  - Prints the contents of a file to `stdout`

```
void
typefile (char *filename)
{
    int fd, nread;
    char buf[1024];

    fd = open (filename, O_RDONLY);
    if (fd == -1) {
        perror (filename);
        return;
    }

    while ((nread = read (fd, buf, sizeof (buf))) > 0)
        write (1, buf, nread);

    close (fd);
}
```

# Different system contexts

- **A system is generally in one of several contexts**
- ***User-level* – CPU in user mode running application**
- **Kernel process context**
  - Running kernel code on behalf of a particular process
  - E.g., performing system call
  - Also exception (mem. fault, numeric exception, etc.)
  - Or executing a kernel-only process (e.g., network file server)
- **Kernel code not associated w. a process**
  - Timer interrupt (hardclock)
  - Device interrupt
  - “Softirqs”, “Tasklets” (Linux-specific terms)
- **Context switch code – changing address spaces**
- **Idle – nothing to do (might powerdown CPU)**

# Transitions between contexts

- **User → kernel process context: syscall, page fault**
- **User/process context → interrupt handler: hardware**
- **Process context → user/context switch: return**
- **Process context → context switch: sleep**
- **Context switch → user/process context**

# CPU preemption

- **Protection mechanism to prevent monopolizing CPU**
- **E.g., kernel programs timer to interrupt every 10 ms**
  - Must be in supervisor mode to write appropriate I/O registers
  - User code cannot re-program interval timer
- **Kernel sets interrupt to vector back to kernel**
  - Regains control whenever interval timer fires
  - Gives CPU to another process if someone else needs it
  - Note: must be in supervisor mode to set interrupt entry points
  - No way for user code to hijack interrupt handler
- **Result: Cannot monopolize CPU with infinite loop**
  - At worst get  $1/N$  of CPU with  $N$  CPU-hungry processes



# Protection is not security

- How *can* you monopolize CPU?

# Protection is not security

- How *can* you monopolize CPU?

- Use multiple processes

- For many years, could wedge most OSes with

```
int main() { while(1) fork(); }
```

- Keeps creating more processes until system out of proc. slots

- Other techniques: use all memory (*chill* program)

- Typically solved with technical/social combination

- Technical solution: Limit processes per user
- Social: Reboot and yell at annoying users

# Address translation

- **Protect memory of one program from actions of another**
- **Definitions**
  - *Address space*: all memory locations a program can name
  - *Virtual address*: addresses in process' address space
  - *Physical address*: address of real memory
  - *Translation*: map virtual to physical addresses
- **Translation done on every load and store**
  - Modern CPUs do this in hardware for speed
- **Idea: If you can't name it, you can't touch it**
  - Ensure one process's translations don't include any other process's memory

# More memory protection

- **CPU allows kernel-only virtual addresses**
  - Kernel typically part of all address spaces, e.g., to handle system call in same address space
  - But must ensure apps can't touch kernel memory
- **CPU lets OS disable (invalidate) particular virtual addresses**
  - Catch and halt buggy program that makes wild accesses
  - Make virtual memory seem bigger than physical (e.g., bring a page in from disk only when accessed)
- **CPU enforced read-only virtual addresses useful**
  - E.g., allows sharing of code pages between processes
  - Plus many other optimizations
- **CPU enforced execute disable of VAs**
  - Makes certain code injection attacks harder

# Resource allocation & performance

- **Multitasking permits higher resource utilization**
- **Simple example:**
  - Process downloading large file mostly waits for network
  - You play a game while downloading the file
  - Higher CPU utilization than if just downloading
- **Complexity arises with cost of switching**
- **Example: Say disk 1,000 times slower than memory**
  - 1 GB memory in machine
  - 2 Processes want to run, each use 1 GB
  - Can switch processes by swapping them out to disk
  - Faster to run one at a time than keep context switching

# Useful properties to exploit

- **Skew**
  - 80% of time taken by 20% of code
  - 10% of memory absorbs 90% of references
  - Basis behind cache: place 10% in fast memory, 90% in slow, usually looks like one big fast memory
- **Past predicts future (a.k.a. temporal locality)**
  - What's the best cache entry to replace?
  - If past  $\approx$  future, then least-recently-used entry
- **Note conflict between fairness & throughput**
  - Higher throughput (fewer cache misses, etc.) to keep running same process
  - But fairness says should periodically preempt CPU and give it to next process