

Midterm results

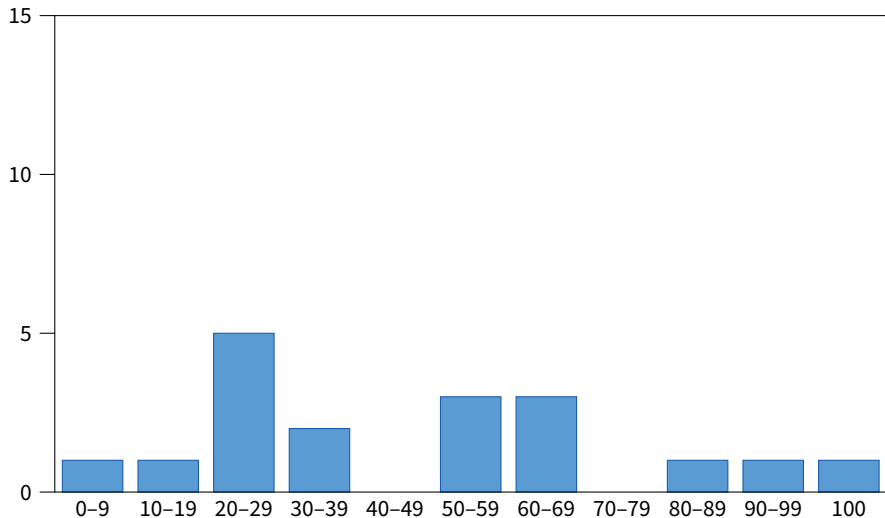

• **Mean: 45.8333, median: 43.0**

Midterm results

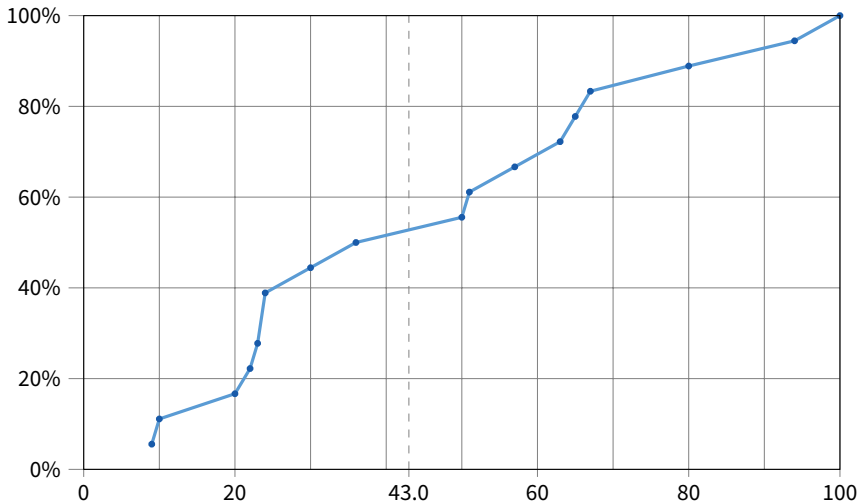

- **Systems students should insist on a CDF!**

Administrivia

- **The point of the exam is to provide signal**
 - These results are more useful than all scores in 80–100
- **Recall we will have a resurrection final**
 - Don't panic if you didn't do well on midterm
 - But make sure you understand all the answers
 - There may be questions on same topics on the final
 - Be sure to attend lecture for resurrection final if you are not CGOE
- **Lab 3 section Friday**

Outline

- 1 PC system architecture
- 2 Driver architecture
- 3 Disks
- 4 Disk scheduling
- 5 Flash

Old-school memory and I/O buses

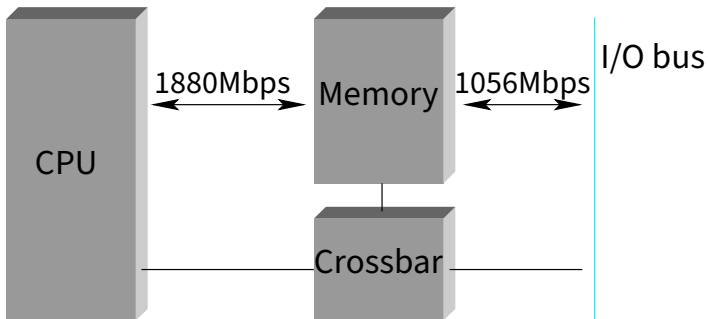

- CPU accesses physical memory over a bus
- Devices access memory over I/O bus with DMA
- Devices can appear to be a region of memory

Realistic ~2005 PC architecture

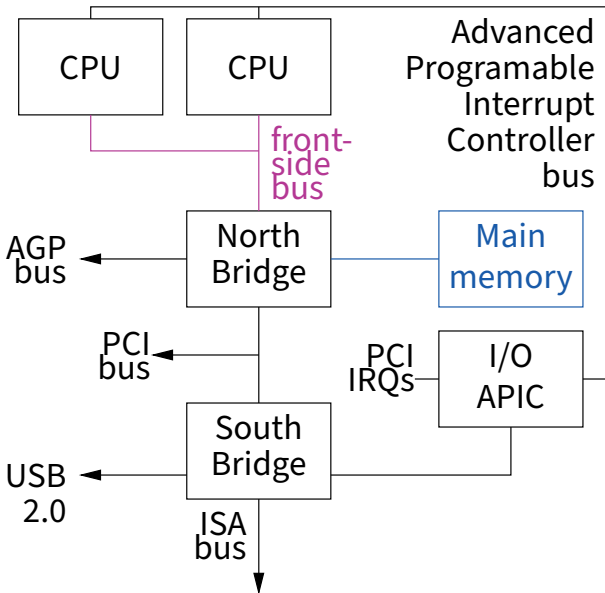

Modern PC architecture (intel)

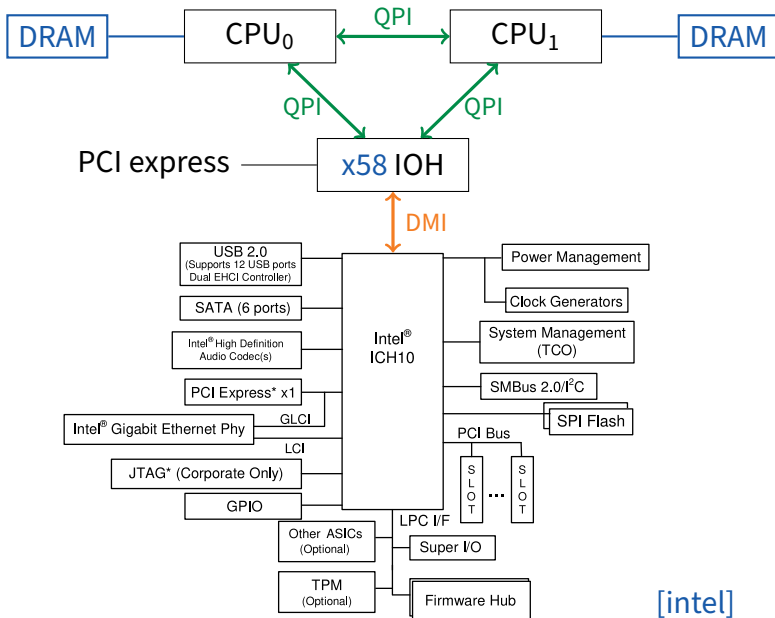

CPU now entirely subsumes IOH [intel]

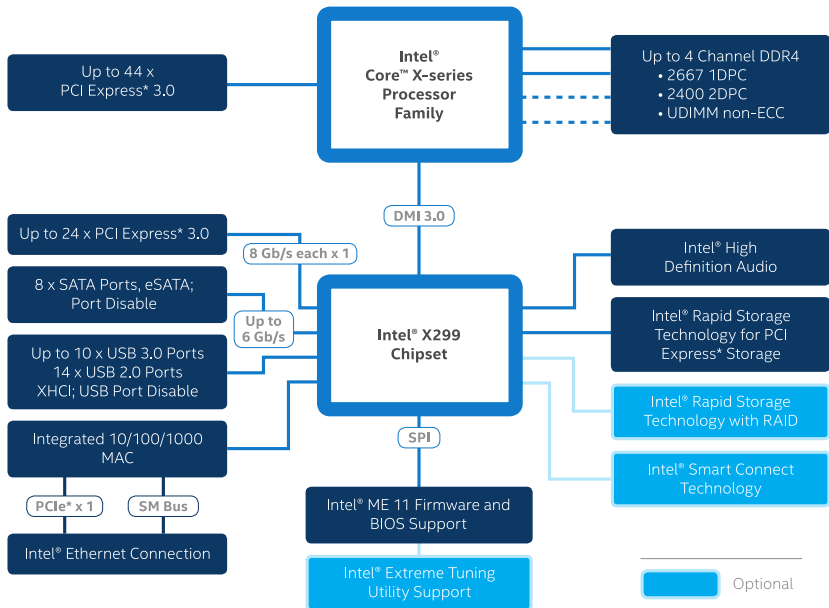

AMD EPYC is essentially an SoC

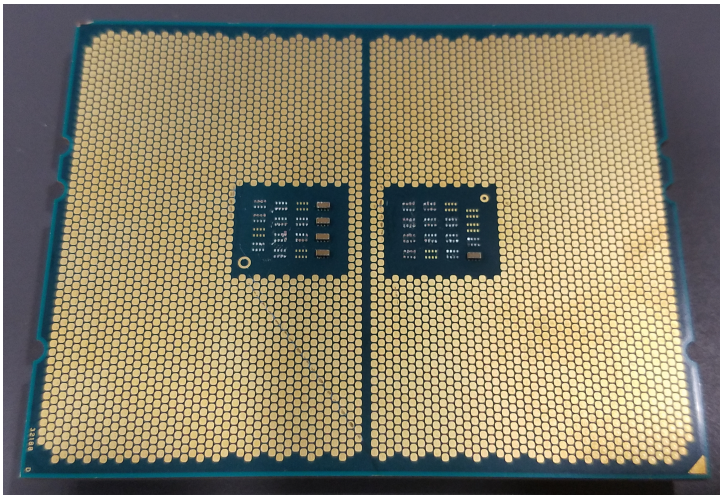

- **4094 pins: both memory controller and 128 lanes PCIe directly on chip!**

What is memory?

- **SRAM – Static RAM**

- Like two NOT gates circularly wired input-to-output
- 4–6 transistors per bit, actively holds its value
- Very fast, used to cache slower memory

- **DRAM – Dynamic RAM**

- A capacitor + gate, holds charge to indicate bit value
- 1 transistor per bit – extremely dense storage
- Charge leaks – need slow comparator to decide if bit 1 or 0
- Must re-write charge after reading, and periodically refresh

- **VRAM – “Video RAM”**

- Dual ported DRAM, can write while someone else reads

What is I/O bus? E.g., PCI

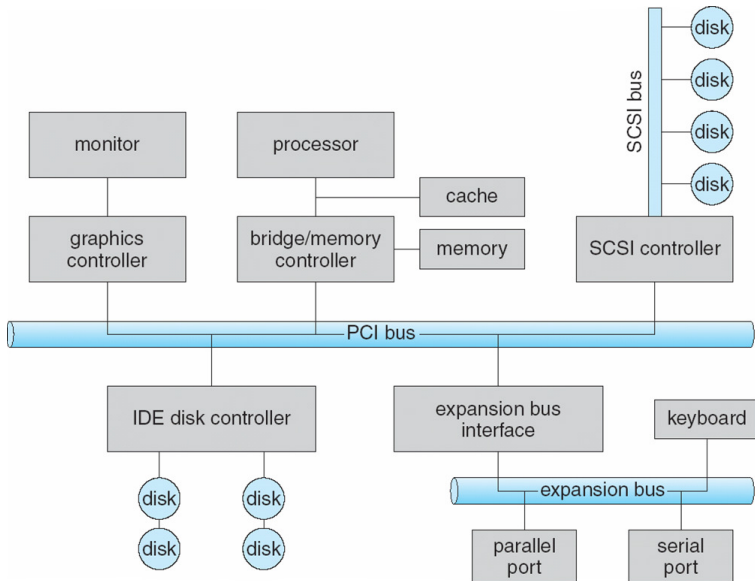

Outline

- 1 PC system architecture
- 2 Driver architecture
- 3 Disks
- 4 Disk scheduling
- 5 Flash

Communicating with a device

- **Memory-mapped device registers**
 - Certain *physical* addresses correspond to device registers
 - Load/store gets status/sends instructions – not real memory
- **Device memory – device may have memory OS can write to directly on other side of I/O bus**
- **Special I/O instructions**
 - Some CPUs (e.g., x86) have special I/O instructions
 - Like load & store, but asserts special I/O pin on CPU
 - OS can allow user-mode access to I/O ports at byte granularity
- **DMA – place instructions to card in main memory**
 - Typically then need to “poke” card by writing to register
 - Overlaps unrelated computation with moving data over (typically slower than memory) I/O bus

x86 I/O instructions

```
static inline uint8_t
inb (uint16_t port)
{
    uint8_t data;
    asm volatile ("inb %w1, %b0" : "=a" (data) : "Nd" (port));
    return data;
}

static inline void
outb (uint16_t port, uint8_t data)
{
    asm volatile ("outb %b0, %w1" : : "a" (data), "Nd" (port));
}

static inline void
insw (uint16_t port, void *addr, size_t cnt)
{
    asm volatile ("rep insw" : "+D" (addr), "+c" (cnt)
                 : "d" (port) : "memory");
}

:
```

Example: parallel port (LPT1)

- Simple hardware has three control registers:

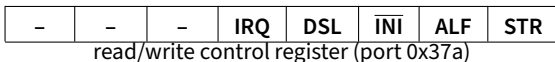
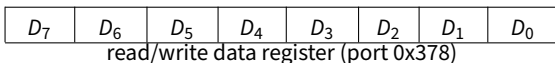

[Messmer]

- Every bit except IRQ corresponds to a pin on 25-pin connector:



[image credits: Wikipedia]

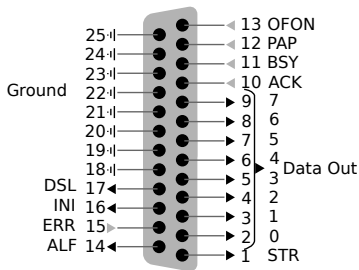

Writing a byte to a parallel port [osdev]

```
void
sendbyte(uint8_t byte)
{
    /* Wait until  $\overline{\text{BSY}}$  bit is 1. */
    while ((inb (0x379) & 0x80) == 0)
        delay ();

    /* Put the byte we wish to send on pins D7-0. */
    outb (0x378, byte);

    /* Pulse STR (strobe) line to inform the printer
     * that a byte is available */
    uint8_t ctrlval = inb (0x37a);
    outb (0x37a, ctrlval | 0x01);
    delay ();
    outb (0x37a, ctrlval);
}
```

IDE disk driver

```
void IDE_ReadSector(int disk, int off, void *buf)
{
    outb(0x1F6, disk == 0 ? 0xE0 : 0xF0); // Select Drive
    IDEWait();
    outb(0x1F2, 1); // Read length (1 sector = 512 B)
    outb(0x1F3, off); // LBA low
    outb(0x1F4, off >> 8); // LBA mid
    outb(0x1F5, off >> 16); // LBA high
    outb(0x1F7, 0x20); // Read command
    insw(0x1F0, buf, 256); // Read 256 words
}
```

```
void IDEWait()
{
    // Discard status 4 times
    inb(0x1F7); inb(0x1F7);
    inb(0x1F7); inb(0x1F7);
    // Wait for status BUSY flag to clear
    while ((inb(0x1F7) & 0x80) != 0)
        ;
}
```

Memory-mapped IO

- **in/out instructions slow and clunky**
 - Instruction format restricts what registers you can use
 - Only allows 2^{16} different port numbers
 - Per-port access control turns out not to be useful (any port access allows you to disable all interrupts)
- **Devices can achieve same effect with physical addresses, e.g.:**

```
volatile int32_t *device_control
    = (int32_t *) (0xc0100 + PHYS_BASE);
*device_control = 0x80;
int32_t status = *device_control;
```

- OS must map physical to virtual addresses, ensure non-cachable
- **Assign physical addresses at boot to avoid conflicts. PCI:**
 - Slow/clunky way to access configuration registers on device
 - Use that to assign ranges of physical addresses to device

DMA buffers

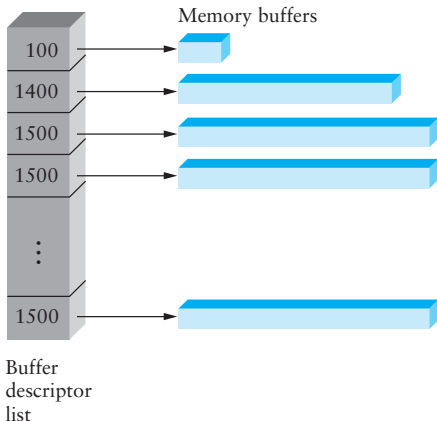

- **Idea: only use CPU to transfer control requests, not data**
- **Include list of buffer locations in main memory**
 - Device reads list and accesses buffers through DMA
 - Descriptions sometimes allow for scatter/gather I/O

Example: Network Interface Card

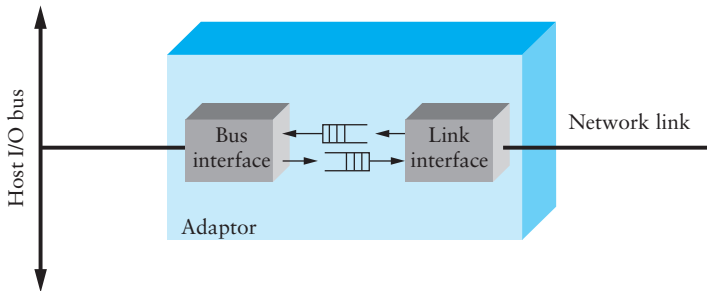

- **Link interface talks to wire/fiber/antenna**
 - Typically does framing, link-layer CRC
- **FIFOs on card provide small amount of buffering**
- **Bus interface logic uses DMA to move packets to and from buffers in main memory**

Example: IDE disk read w. DMA

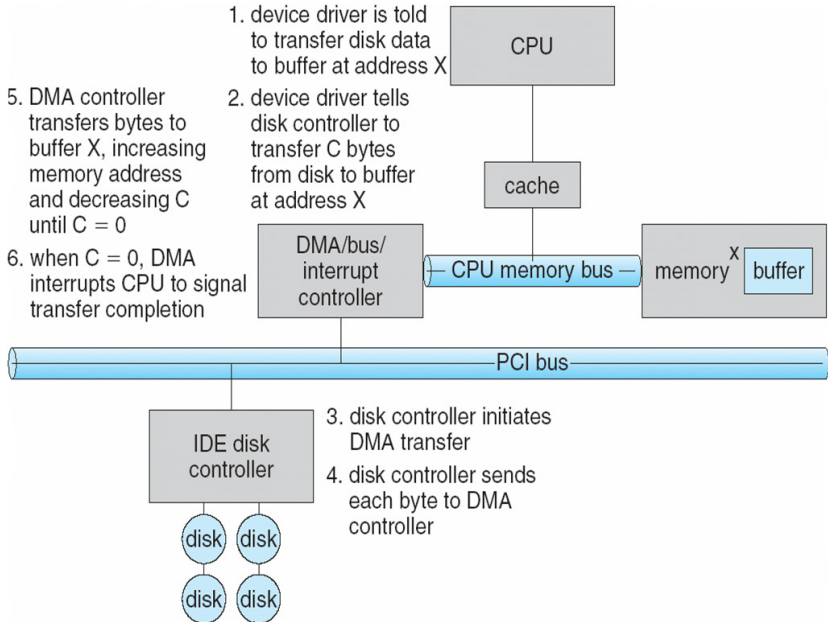

Driver architecture

- **Device driver provides several entry points to kernel**
 - Reset, ioctl, output, interrupt, read, write, strategy ...
- **How should driver synchronize with card?**
 - E.g., Need to know when transmit buffers free or packets arrive
 - Need to know when disk request complete
- **One approach: *Polling***
 - Sent a packet? Loop asking card when buffer is free
 - Waiting to receive? Keep asking card if it has packet
 - Disk I/O? Keep looping until disk ready bit set
- **Disadvantages of polling?**

Driver architecture

- **Device driver provides several entry points to kernel**
 - Reset, ioctl, output, interrupt, read, write, strategy ...
- **How should driver synchronize with card?**
 - E.g., Need to know when transmit buffers free or packets arrive
 - Need to know when disk request complete
- **One approach: *Polling***
 - Sent a packet? Loop asking card when buffer is free
 - Waiting to receive? Keep asking card if it has packet
 - Disk I/O? Keep looping until disk ready bit set
- **Disadvantages of polling?**
 - Can't use CPU for anything else while polling
 - Schedule poll in future? High latency to receive packet or process disk block bad for response time

Interrupt driven devices

- **Instead, ask card to interrupt CPU on events**
 - Interrupt handler runs at high priority
 - Asks card what happened (xmit buffer free, new packet)
 - This is what most general-purpose OSes do
- **Bad under high network packet arrival rate**
 - Packets can arrive faster than OS can process them
 - Interrupts are expensive
 - Interrupt handlers have high priority
 - In worst case, can spend 100% of time in interrupt handler and never make any progress – *receive livelock*
 - Best: Adaptive switching between interrupts and polling
- **Very good for disk requests**
- **Rest of today: Disks (network devices in 3 lectures)**

Outline

- 1 PC system architecture
- 2 Driver architecture
- 3 Disks
- 4 Disk scheduling
- 5 Flash

- **Stack of magnetic platters**
 - Rotate together on a central spindle @3,600-15,000 RPM
 - Drive speed drifts slowly over time
 - Can't predict rotational position after 100-200 revolutions
- **Disk arm assembly**
 - Arms rotate around pivot, all move together
 - Pivot offers some resistance to linear shocks
 - One disk head per recording surface (2×platters)
 - Sensitive to motion and vibration [[Gregg](#)] ([demo on youtube](#))

Disk

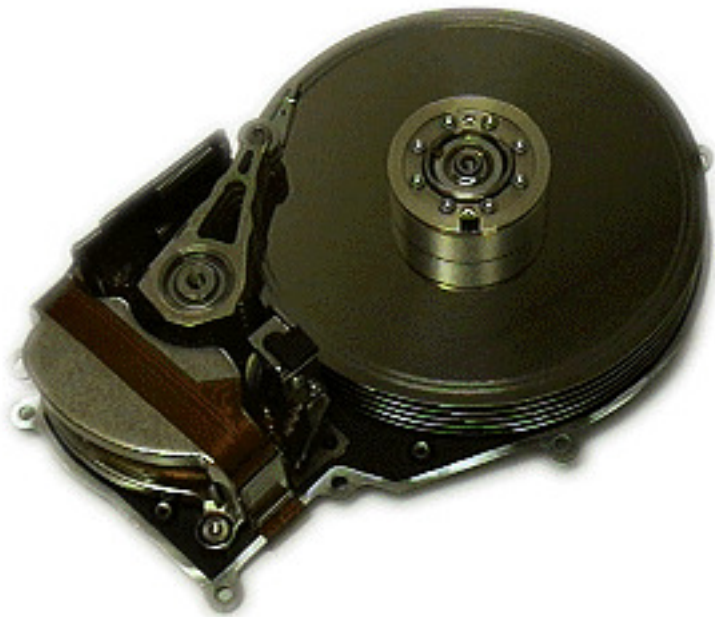

Disk



Disk

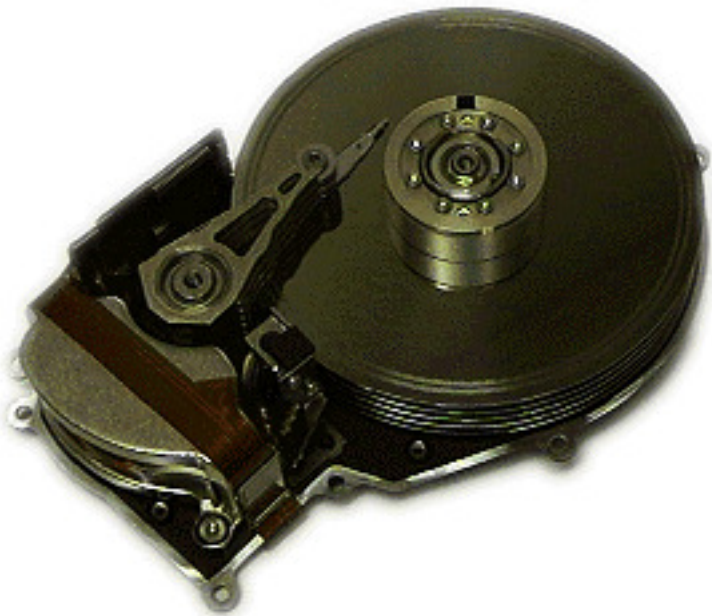

Storage on a magnetic platter

- **Platters divided into concentric *tracks***
- **A stack of tracks of fixed radius is a *cylinder***
- **Heads record and sense data along cylinders**
 - Significant fractions of encoded stream for error correction
- **Generally only one head active at a time**
 - Disks usually have one set of read-write circuitry
 - Must worry about cross-talk between channels
 - Hard to keep multiple heads exactly aligned

Cylinders, tracks, & sectors

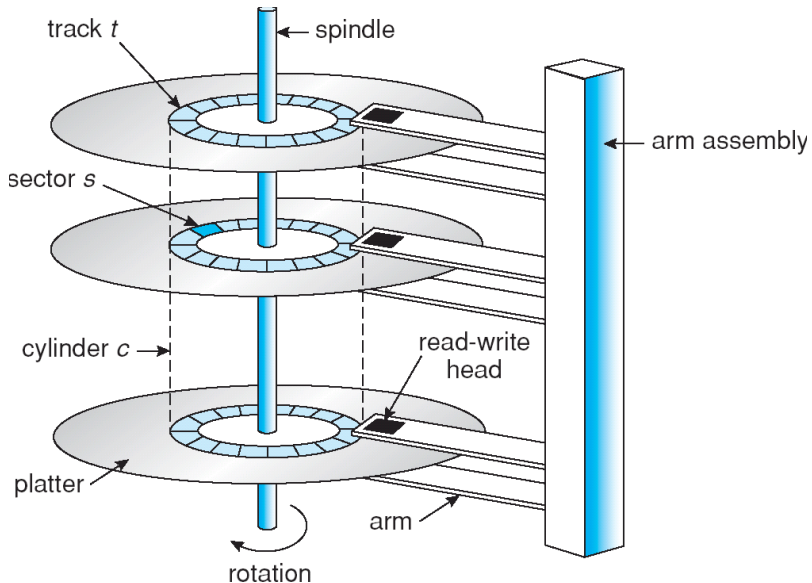

Disk positioning system

- **Move head to specific track and keep it there**
 - Resist physical shocks, imperfect tracks, etc.
- **A seek consists of up to four phases:**
 - *speedup*—accelerate arm to max speed or half way point
 - *coast*—at max speed (for long seeks)
 - *slowdown*—stops arm near destination
 - *settle*—adjusts head to actual desired track
- **Very short seeks dominated by settle time (~ 1 ms)**
- **Short (200-400 cyl.) seeks dominated by speedup**
 - Accelerations of 40g

Seek details

- **Head switches comparable to short seeks**
 - May also require head adjustment
 - Settles take longer for writes than for reads – Why?

- **Disk keeps table of pivot motor power**
 - Maps seek distance to power and time
 - Disk interpolates over entries in table
 - Table set by periodic “thermal recalibration”
 - But, e.g., ~500 ms recalibration every ~25 min bad for AV

- **“Average seek time” quoted can be many things**
 - Time to seek 1/3 disk, 1/3 time to seek whole disk

Seek details

- **Head switches comparable to short seeks**
 - May also require head adjustment
 - Settles take longer for writes than for reads
 - If read strays from track, catch error with checksum, retry
 - If write strays, you've just clobbered some other track
- **Disk keeps table of pivot motor power**
 - Maps seek distance to power and time
 - Disk interpolates over entries in table
 - Table set by periodic “thermal recalibration”
 - But, e.g., ~500 ms recalibration every ~25 min bad for AV
- **“Average seek time” quoted can be many things**
 - Time to seek 1/3 disk, 1/3 time to seek whole disk

Sectors

- **Disk interface presents linear array of sectors**
 - Historically 512 B, but 4 KiB in “**advanced format**” disks
 - Written atomically (even if there is a power failure)
- **Disk maps logical sector #s to physical sectors**
 - *Zoning*–puts more sectors on longer tracks
 - *Track skewing*–sector 0 pos. varies by track (why?)
 - *Sparing*–flawed sectors remapped elsewhere
- **OS doesn't know logical to physical sector mapping**
 - Larger logical sector # difference means longer seek time
 - Highly non-linear relationship (*and* depends on zone)
 - OS has no info on rotational positions
 - Can empirically build table to estimate times

Sectors

- **Disk interface presents linear array of sectors**
 - Historically 512 B, but 4 KiB in “**advanced format**” disks
 - Written atomically (even if there is a power failure)
- **Disk maps logical sector #s to physical sectors**
 - *Zoning*–puts more sectors on longer tracks
 - *Track skewing*–sector 0 pos. varies by track (sequential access speed)
 - *Sparing*–flawed sectors remapped elsewhere
- **OS doesn't know logical to physical sector mapping**
 - Larger logical sector # difference means longer seek time
 - Highly non-linear relationship (*and* depends on zone)
 - OS has no info on rotational positions
 - Can empirically build table to estimate times

Disk interface

- Controls hardware, mediates access
- Computer, disk often connected by bus (e.g., ATA, SCSI, SATA)
 - Multiple devices may contend for bus
- **Possible disk/interface features:**
- Disconnect from bus during requests
- Command queuing: Give disk multiple requests
 - Disk can schedule them using rotational information
- Disk cache used for read-ahead
 - Otherwise, sequential reads would incur whole revolution
 - Cross track boundaries? Can't stop a head-switch
- Some disks support write caching
 - But data not stable—not suitable for all requests

Disk performance

- **Placement & ordering of requests a huge issue**
 - Sequential I/O much, much faster than random
 - Long seeks much slower than short ones
 - Power might fail any time, leaving inconsistent state
- **Must be careful about order for crashes**
 - More on this in next two lectures
- **Try to achieve contiguous accesses where possible**
 - E.g., make big chunks of individual files contiguous
- **Try to order requests to minimize seek times**
 - OS can only do this if it has multiple requests to order
 - Requires disk I/O concurrency
 - High-performance apps try to maximize I/O concurrency
- **Next: How to schedule concurrent requests**

Outline

- 1 PC system architecture
- 2 Driver architecture
- 3 Disks
- 4 Disk scheduling
- 5 Flash

Scheduling: FCFS

- **“First Come First Served”**
 - Process disk requests in the order they are received
- **Advantages**

- **Disadvantages**

- **“First Come First Served”**
 - Process disk requests in the order they are received
- **Advantages**
 - Easy to implement
 - Good fairness
- **Disadvantages**
 - Cannot exploit request locality
 - Increases average latency, decreasing throughput

FCFS example

queue = 98, 183, 37, 122, 14, 124, 65, 67
head starts at 53

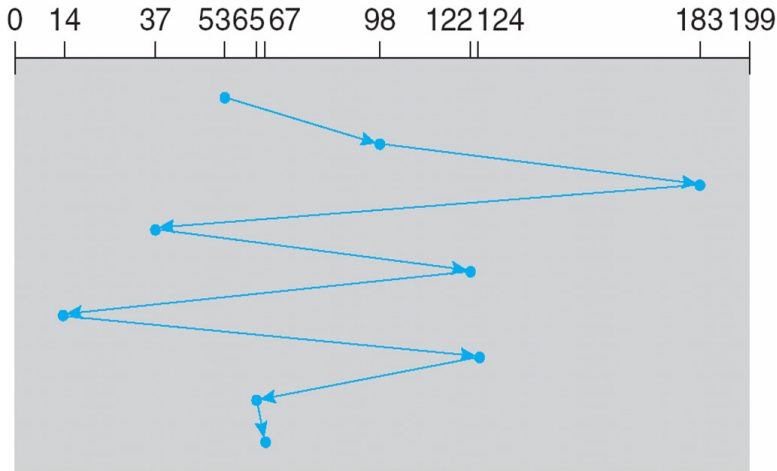

Shortest positioning time first (SPTF)

- **Shortest positioning time first (SPTF)**
 - Always pick request with shortest seek time
- **Also called Shortest Seek Time First (SSTF)**
- **Advantages**

- **Disadvantages**

Shortest positioning time first (SPTF)

- **Shortest positioning time first (SPTF)**
 - Always pick request with shortest seek time
- **Also called Shortest Seek Time First (SSTF)**
- **Advantages**
 - Exploits locality of disk requests
 - Higher throughput
- **Disadvantages**
 - Starvation
 - Don't always know what request will be fastest
- **Improvement?**

Shortest positioning time first (SPTF)

- **Shortest positioning time first (SPTF)**
 - Always pick request with shortest seek time
- **Also called Shortest Seek Time First (SSTF)**
- **Advantages**
 - Exploits locality of disk requests
 - Higher throughput
- **Disadvantages**
 - Starvation
 - Don't always know what request will be fastest
- **Improvement: Aged SPTF**
 - Give older requests higher priority
 - Adjust “effective” seek time with weighting factor:
$$T_{\text{eff}} = T_{\text{pos}} - W \cdot T_{\text{wait}}$$

SPTF example

queue = 98, 183, 37, 122, 14, 124, 65, 67
head starts at 53

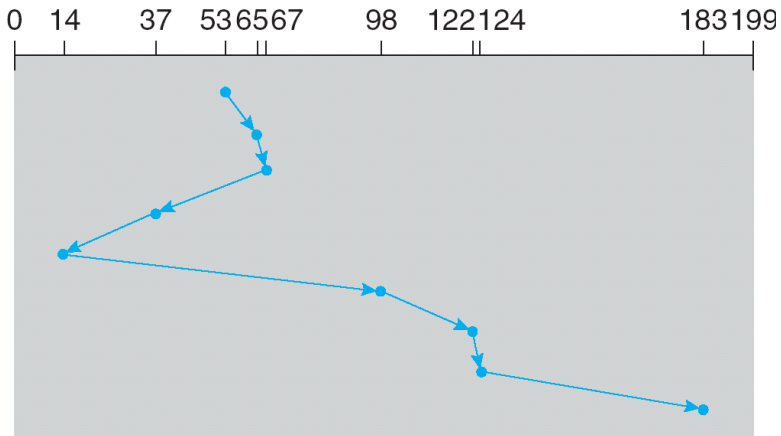

“Elevator” scheduling (SCAN)

- **Sweep across disk, servicing all requests passed**
 - Like SPTF, but next seek must be in same direction
 - Switch directions only if no further requests
- **Advantages**

- **Disadvantages**

“Elevator” scheduling (SCAN)

- **Sweep across disk, servicing all requests passed**
 - Like SPTF, but next seek must be in same direction
 - Switch directions only if no further requests
- **Advantages**
 - Takes advantage of locality
 - Bounded waiting
- **Disadvantages**
 - Cylinders in the middle get better service
 - Might miss locality SPTF could exploit
- **CSCAN: Only sweep in one direction**
Very commonly used algorithm in Unix
- **Also called LOOK/CLOOK in textbook**
 - (Textbook uses [C]SCAN to mean scan entire disk uselessly)

CSCAN example

queue 98, 183, 37, 122, 14, 124, 65, 67

head starts at 53

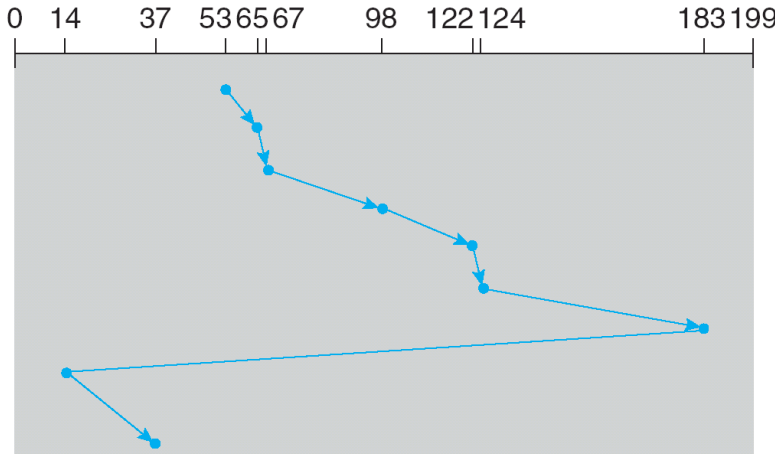

- **Continuum between SPTF and SCAN**
 - Like SPTF, but slightly changes “effective” positioning time
If request in same direction as previous seek: $T_{\text{eff}} = T_{\text{pos}}$
Otherwise: $T_{\text{eff}} = T_{\text{pos}} + r \cdot T_{\text{max}}$
 - when $r = 0$, get SPTF, when $r = 1$, get SCAN
 - E.g., $r = 0.2$ works well
- **Advantages and disadvantages**
 - Those of SPTF and SCAN, depending on how r is set
- See [[Worthington](#)] for good description and evaluation of various disk scheduling algorithms

Outline

- 1 PC system architecture
- 2 Driver architecture
- 3 Disks
- 4 Disk scheduling
- 5 **Flash**

Flash memory

- Today, people increasingly using flash memory
- Completely solid state (no moving parts)
 - Remembers data by storing charge
 - Lower power consumption and heat
 - No mechanical seek times to worry about
- Limited # overwrites possible
 - Blocks wear out after 10,000 (MLC) – 100,000 (SLC) erases
 - Requires *flash translation layer* (FTL) to provide *wear leveling*, so repeated writes to logical block don't wear out physical block
 - FTL can seriously impact performance
 - In particular, random writes *very expensive* [Birrell]
- Limited durability
 - Charge wears out over time
 - Turn off device for a year, you can potentially lose data

Types of flash memory

- **NAND flash (most prevalent for storage)**
 - Higher density (most used for storage)
 - Faster erase and write
 - More errors internally, so need error correction
- **NOR flash**
 - Faster reads in smaller data units
 - Can execute code straight out of NOR flash
 - Significantly slower erases
- **Single-level cell (SLC) vs. Multi-level cell (MLC)**
 - MLC encodes multiple (two) bits in voltage level
 - MLC slower to write than SLC
 - MLC has lower durability (bits decay faster)
- **Nowadays, most flash drives are TLC, QLC, soon PLC**

NAND Flash Overview

- **Flash device has 2112-byte *pages***
 - 2048 bytes of data + 64 bytes metadata & ECC
- ***Blocks* contain 64 (SLC) or 128 (MLC) *pages***
- ***Blocks* segregated into 2–4 *planes***
 - All planes contend for same package pins
 - But can access their blocks in parallel to overlap latencies
- **Can *read* one *page* at a time**
 - Takes 25 μ sec + time to get data off chip
- **Must *erase* whole *block* before *programming***
 - Historically 256 KiB–4 MiB, now trending higher towards 1 GiB
 - Erase sets all bits to 1—very expensive (2 msec)
 - Programming pre-erased block requires moving data to internal buffer, then 200 (SLC)–800 (MLC) μ sec
 - Note SMR magnetic drives starting to behave like this, too!

Flash Characteristics [Caulfield'09]

Parameter	SLC	MLC
Density Per Die (GB)	4	8
Page Size (Bytes)	2048+32	2048+64
Block Size (Pages)	64	128
Read Latency (μ s)	25	25
Write Latency (μ s)	200	800
Erase Latency (μ s)	2000	2000
40MHz, 16-bit bus Read b/w (MB/s)	75.8	75.8
Program b/w (MB/s)	20.1	5.0
133MHz Read b/w (MB/s)	126.4	126.4
Program b/w (MB/s)	20.1	5.0

FTL straw man: in-memory map

- **Keep in-memory map of logical \rightarrow physical page #**
 - On write, pick unused page, mark previous physical page free
 - Repeated writes of a logical page will hit different physical pages
- **Store map in device memory, but must rebuild on power-up**
- **Idea: Put header on each page, scan all headers on power-up:**
(**logical page #**, Allocated bit, Written bit, Obsolete bit)
 - A-W-O = 1-1-1: free page
 - A-W-O = 0-1-1: about to write page
 - A-W-O = 0-0-1: successfully written page
 - A-W-O = 0-0-0: obsolete page (can erase block without copying)
- **Why the 0-1-1 state?**
- **What's wrong still?**

FTL straw man: in-memory map

- **Keep in-memory map of logical \rightarrow physical page #**
 - On write, pick unused page, mark previous physical page free
 - Repeated writes of a logical page will hit different physical pages
- **Store map in device memory, but must rebuild on power-up**
- **Idea: Put header on each page, scan all headers on power-up:**
(**logical page #**, Allocated bit, Written bit, Obsolete bit)
 - A-W-O = 1-1-1: free page
 - A-W-O = 0-1-1: about to write page
 - A-W-O = 0-0-1: successfully written page
 - A-W-O = 0-0-0: obsolete page (can erase block without copying)
- **Why the 0-1-1 state?** After power failure partly written \neq free
- **What's wrong still?**

FTL straw man: in-memory map

- **Keep in-memory map of logical \rightarrow physical page #**
 - On write, pick unused page, mark previous physical page free
 - Repeated writes of a logical page will hit different physical pages
- **Store map in device memory, but must rebuild on power-up**
- **Idea: Put header on each page, scan all headers on power-up:**
(**logical page #**, Allocated bit, Written bit, Obsolete bit)
 - A-W-O = 1-1-1: free page
 - A-W-O = 0-1-1: about to write page
 - A-W-O = 0-0-1: successfully written page
 - A-W-O = 0-0-0: obsolete page (can erase block without copying)
- **Why the 0-1-1 state?** After power failure partly written \neq free
- **What's wrong still?**
 - FTL requires a lot of RAM on device, plus time to scan all headers
 - Some blocks still get erased more than others (w. long-lived data)
 - Blocks with obsolete pages may also contain live pages

More realistic FTL

- **Store the FTL map in the flash device itself**
 - Add one header bit to distinguish map page from data page
 - Logical read may miss map cache, require 2 flash reads
 - Keep smaller “map-map” in memory, cache some map pages
- **Must garbage-collect blocks with obsolete pages**
 - Copy live pages to a new block, erase old block
 - Always need free blocks, can't use 100% physical storage
- **Problem: write amplification**
 - Small random writes punch holes in many blocks
 - If small writes require garbage-collecting a 90%-full blocks
... means you are writing 10× more physical than logical data!
- **Must also periodically re-write even blocks w/o holes**
 - *Wear leveling* ensures active blocks don't wear out first